

# White paper – Guidelines for evaluating Indice’s MR16 LED downlights



**Important configuration note before powering up:** Before powering the control board, ensure a LED with  $20 < V_f < 30$  is connected to the output (The standard LED in the product is 28V). In the event the control board is powered up without an LED connected, the control board will go into an overvoltage condition and suffer irreversible damage.

**Evaluating dimming performance:** Leading and trailing edge dimmers typically require minimum quiescent current draw to ensure they latch and fire appropriately at the right phase angle every cycle. Depending on the dimmer power rating this may range of 25W to 80W. As a general rule we recommend a dimmer circuit loaded with a minimum of 3 LED downlights per dimmer circuit as per the diagram below. Note that a leading or triac dimmer should never be used with electronic transformers, and trailing or electronic dimmers should never be used with magnetic transformers.

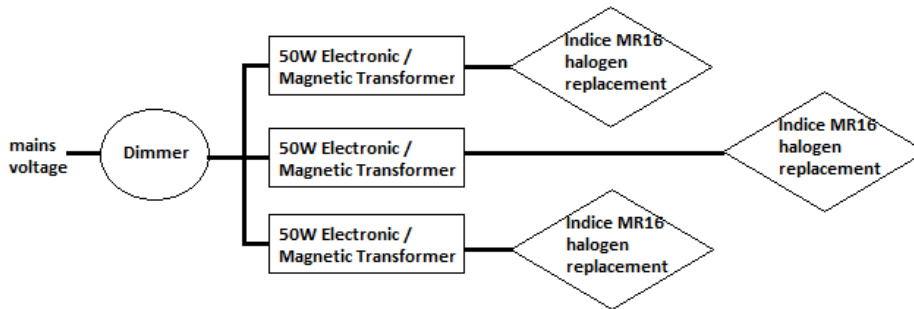

Figure 1: Recommended configuration for evaluating dimmer performance

**Transformer compatibility testing:** Indice’s LED controller is compatible with electronic and magnetic transformers. To verify compatibility on various transformers, Indice recommends 1 lamp per 50W of transformer power rating. For example, a 100W transformer typically has 2 or more halogens connected and we test these with 2 Indice LED lamps.

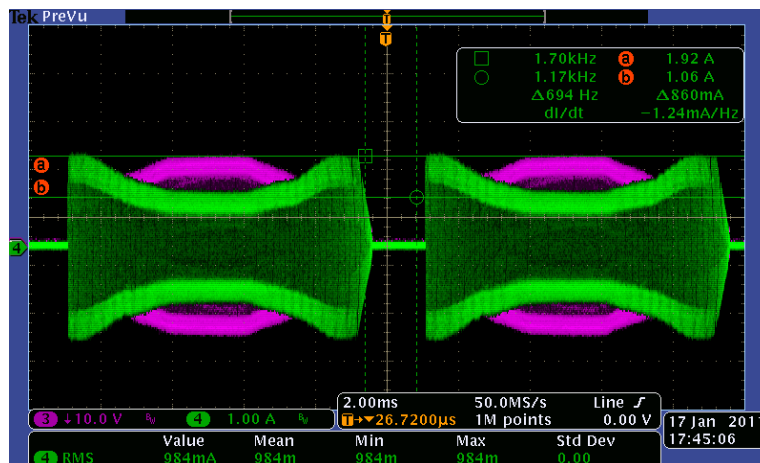
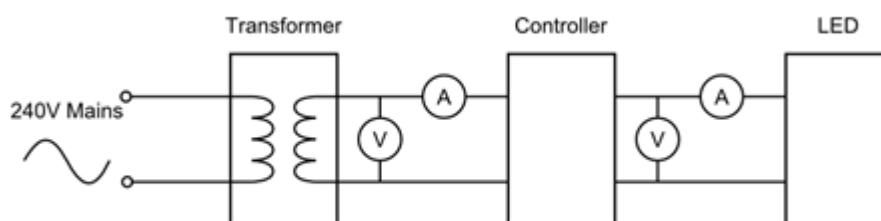

Figure 2: Output Current (GREEN) and voltage (PURPLE) waveforms from a Lucci TB60L electronic transformer (Measured off the MR16 wires)

**Measuring control board efficiency:** When measuring efficiency of the LED control board, it is critical to use a 10MHz or higher bandwidth power analyser. This is necessary, particularly on electronic transformers as the voltage and current waveforms are switching at hundreds of kilohertz on some devices. Measuring power between the transformer and the control board with a multimeter or low bandwidth meter will result in incorrect readings.



**Figure 3: Measurement of LED control board efficiency**

**Measuring Power factor:** Power factor is always measured on the 240V or 110V supply side of the electronic or magnetic transformer. Measuring power factor between the transformer and lamp will give you a value that has little meaning. Indice has measured power factor on many electronic transformers with values of 0.8 to 0.9 typically found.

**Requirements for 110V and 240V systems:** There is one magnetic part variation between 12VAC/MR16 halogen transformers on 110V (100V-120V) and 240V (220V – 240V) systems. This is necessary to match the different winding ratios of 110V transformers which differ significantly from 240V transformers. Ensure the LED lamp you are using is designated for either a 110V or 240V transformer system.

**Verifying EMC Compliance:** Indice's LED controller is compliant with the Class B requirements for CISPR22 and FCC Part 15. To maintain this compliance the product must be tested fully assembled.